

"P" PROFILE - TOOL LIST ONLY; EXTRUSIONS NOT HELD IN STOCK

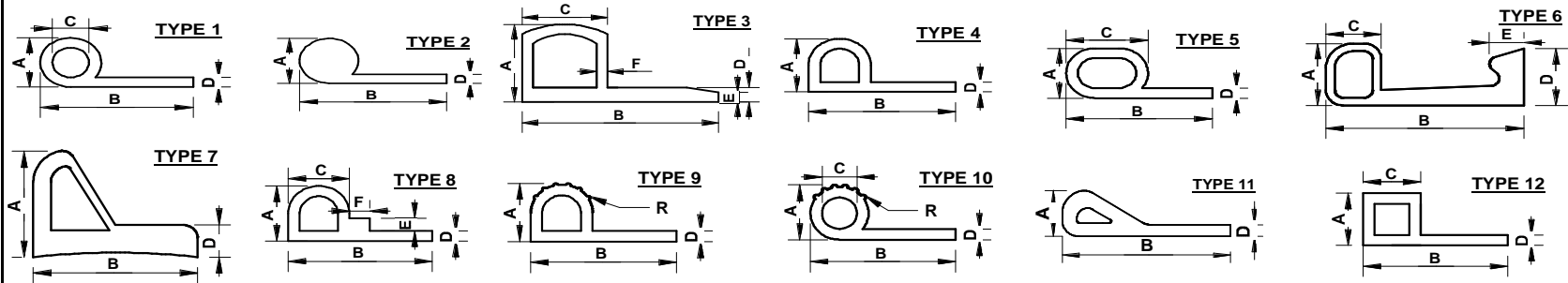

DATE: 27.08.09 ISS4 (UP TO DIE 2737/SB)

DIE #	TYPE	HARDNESS	A	B	C	D	E	F	R
1292/SB	2	30	2.1	13		1			
1000/SB	4	20	2.5	10		5		SOLID	
2658/SB	4	60	4	9		1			
2316/SB	1	THT	5.5	8	4.1	0.25			
848/SB	4	60	5.5	33		2		1.5	
1453/SB	1	50	6	18	3	1.5			
1238/SB	1	50	6	19.5	3	1.5			
1213/SW	11	60	6	20		1.5			
1680/SB	1	60	6	21.5	4	1			
1455/SB	2	60	6	29		2			
622/SB	1	60	6	38	3	2			
2022/SB	1	50	6.2	14.5	3	1.5			
1142/SB	1	50	6.35	15.88	3.31	1.52			
1765/SB	4	60	6.35	19		1.5			
53/SW	1	60	6.35	19	3.8	1.27			
1656/SB	1	40	6.35	20.4	3.1	1.6			
2326/SB	1	60	7	10	3	2			
227/SB	1	80	7	27	3	2			
1423/SW	8	60	7	30		2	1	2	
1310/SB	2	70	7.87	27		3-4			
320/SB	4	60	8	12	6 BULB	4		SOLID	
2045/SB	1	55	8	20	6	1			

"P" PROFILE - TOOL LIST ONLY; EXTRUSIONS NOT HELD IN STOCK

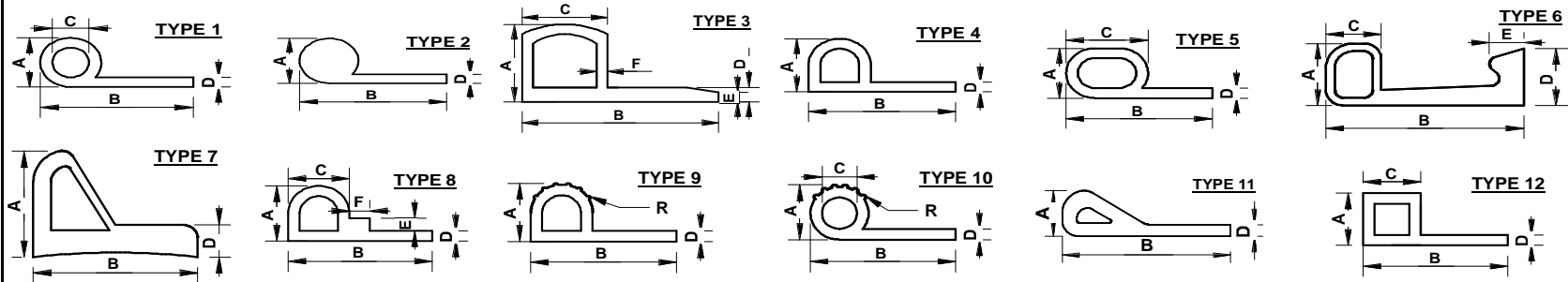

DATE: 27.08.09 ISS4 (UP TO DIE 2737/SB)

DIE #	TYPE	HARDNESS	A	B	C	D	E	F	R
528/SB	2	60	8	25		4			
1077/SB	1	60	8	25	6	1			
1293/SB	4	60	8	25		3			
1305/SB	1	60	8.5	20.5	6.5	1.7			
1512/SB	1	60	9	22	7	1			
1794/SB	1	60	9	26	6	2			
658/SW	1	60	9	26.5	7	1.8			
242/SB	1	80	9	29	5	2			
1787/SB	1	60	9	30	3	3			
114/SB	1	60	9	30	5	2			
1722/SB	1	60	9	40	3	3			
314/SB	1	60	9.5	25.5	6	1.5			
127/SW	1	60	9.6	30	5	2.5			
1368/SB	1	60	10	20	8.2	0.9			
234/SB	1	50	10	20	7	1.5			
1241/SB	1	60	10	25	6	2			
1510/SB	1	60	10	27	8	1			
930/SB	1	45	10	29	6	2.25			
926/SB	1	60	10	29	6	2			
1336/SB	1	60	10	30	6	2			
1328/SB	1	60	10	32	4	3			
1610/SB	1	60	10	35	8	1			

"P" PROFILE - TOOL LIST ONLY; EXTRUSIONS NOT HELD IN STOCK

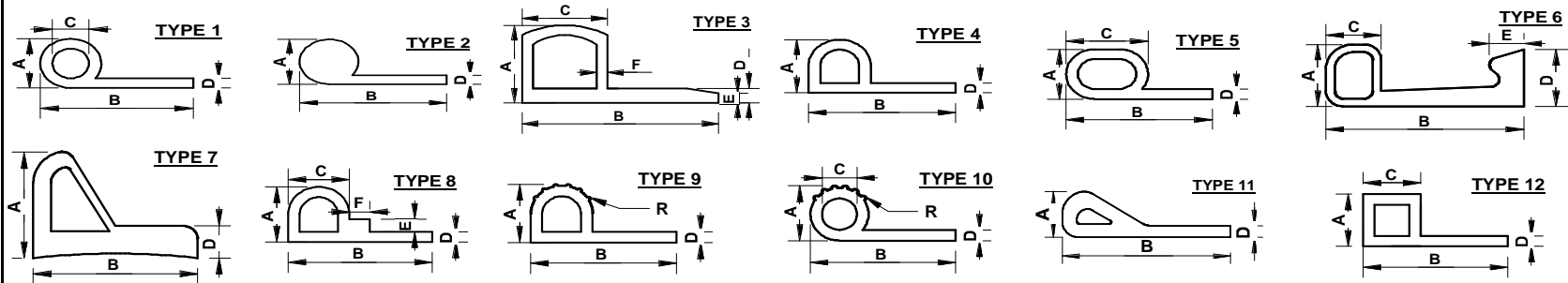

DATE: 27.08.09 ISS4 (UP TO DIE 2737/SB)

DIE #	TYPE	HARDNESS	A	B	C	D	E	F	R
1147/SB	1	60	11	24.5	8	2			
806/SB	4	60	11	30		3			
323/SB	1	60	11.1	15.88	8.05	1.52			
404/SB	4	50	12	20		2			
592/SB	1	60	12	22	8	2			
999/SB	1	60	12	23	9	1.5			
1332/SB	1	60	12	25	10	1			
428/SB	1	60	12	30	6	2			
163/SB	4	60	12	32		1.75			
1922/SB	6	45	12	34	9.5	3	7.2		
1708/SW	1	60	12	34	6	3			
1074/SB	1	40	12	36	7.5	3			
1404/SB	1	60	12	37	6	3			
223/SB	2	45	12	38		3			
939/SW	1	50	12.2	25	8.2	1.5			
1584/SB	2	60	12.5	27.5		3			
1766/SB	1	60	12.7	26.9	9.55	1.6			
14/SB	1	60	12.7	29.5	6.7	3			
1481/SB	1	50	13	22	10	1.5			
1347/SB	1	60	13	26.5	9	2			
335/SB	12	50	13	33	12	1.5			
508/SB	4	60	13	34		3			

"P" PROFILE - TOOL LIST ONLY; EXTRUSIONS NOT HELD IN STOCK

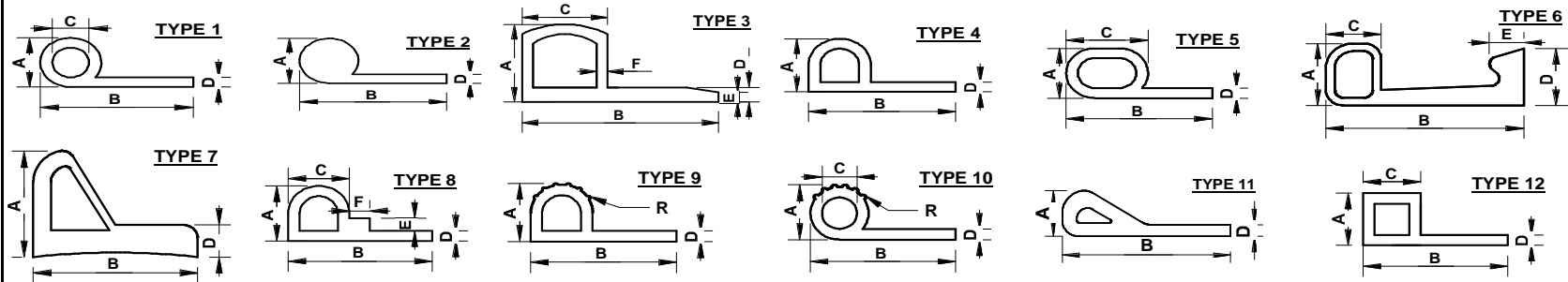

DATE: 27.08.09 ISS4 (UP TO DIE 2737/SB)

DIE #	TYPE	HARDNESS	A	B	C	D	E	F	R
455/SB	1	50	13.5	29.5	2	2			
1249/SB	1	60	13.5	32	8.5	2.5			
1543/SB	1	50	14	30	8	3			
273/SB	1	60	14	32	11	1.5			
846/SB	1	60	14	32	10	2			
846/SB	1	55	14	32	10	2			
2074/SB	1	60	14	33	6	3			
1842/SB	1	60	15	30	12	1.5			
2737/SB	1	60	15	35	11	2			
130/SB	1	70	15	37	6	3			
1030/SB	1	60	15	39	9	3			
676/SB	1	60	15	58	9	3			
676/SB	1	50	15	58	9	3			
480/SB	1	60	15.5	31	11.5	1.6			
2168/SB	9	60	16.5	35.5		2.5			8.75
1330/SB	1	50	16	34	12	1.5			
1726/SB	3	60	16	37	14	3	2	2	
756/SB	1	60	16	40	10	2			
1886/SB	4	60	18	27.5		1.5			
780/SB	4	60	18	28		2			
1651/SW	9	60	18	50		3			9
571/SB	1	80	19	29	13	3			

"P" PROFILE - TOOL LIST ONLY; EXTRUSIONS NOT HELD IN STOCK

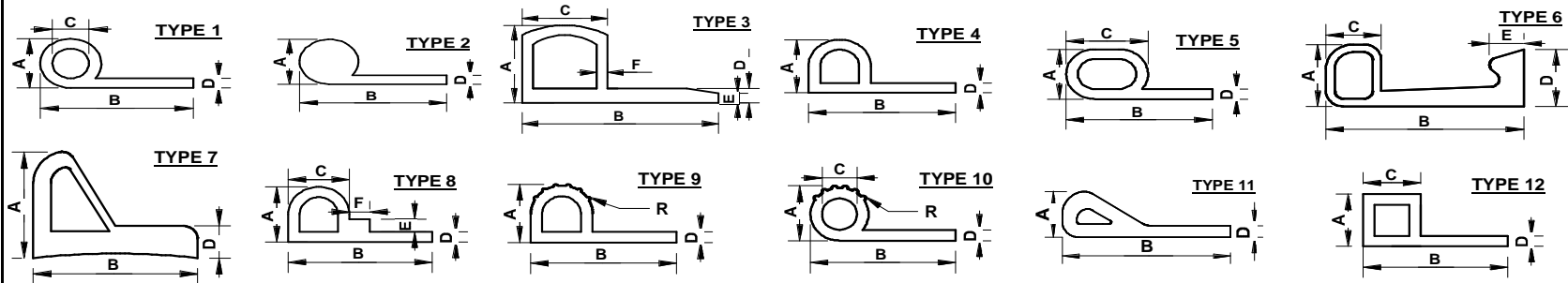

DATE: 27.08.09 ISS4 (UP TO DIE 2737/SB)

DIE #	TYPE	HARDNESS	A	B	C	D	E	F	R
488/SW	12	65	19	38	19	4.8			
571/SB	1	60	19	38	13	3			
2235/SB	1	60	19	41	13	3			
1263/SW	7	70	20	28		6			
1681/SW	1	60	20	35	15	2.5			
546/SB	1	70	25	38	20	2.5			
2222/SB	1	60	25	52.5	17	5			
522/SW	1	60	25.4	25.4	15.9	4.8			
1317/SB	1	60	36	70	28	10			